

## Low Profile Single-Point

### FEATURES

- Capacities: 0.6 to 200 kg
- Small size with low profile
- Anodized aluminum
- NTEP Class III 5000S approval from 3 kg to 30 kg
- OIML C3 approval from 6 kg to 35 kg
- Platform size: 16"x16"/ 40 cm x 40 cm
- **Optional**
  - FM approval available

### APPLICATIONS

- Packaging machines
- Dosing/filling
- Belt scales/conveyor scales
- In-motion check weigher
- Retail scales/counting scales

### DESCRIPTION

LPS is designed for electronic scales and platform scales where only one load cell can be used and low profile is required. It is the lightest model of Celtron single-point

load cell family. The design is most suitable for mass production operations.

LPS is constructed of anodized aluminum and is fully potted IP66 levels, providing excellent protection against moisture ingress.



### OUTLINE DIMENSIONS

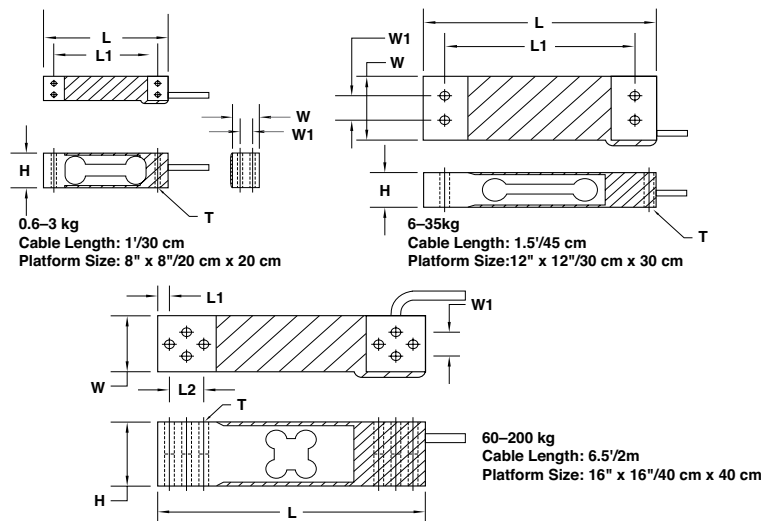

#### Wiring diagram

- + Excitation Red
- Excitation Black
- + Signal Green
- Signal White

CAPACITY (kg)		L	L <sub>1</sub>	L <sub>2</sub>	W	W <sub>1</sub>	H	T
0.6/1/2/3	mm	70.0	58.0	–	15.0	7.0	22.0	M3 x 0.5
	(inch)	2.76	2.28	–	0.59	0.28	0.87	
6/10/15/20	mm	130.0	106.0	–	30.0	15.0	22.0	M6 x 1.0
	(inch)	5.12	4.17	–	1.18	0.59	0.87	
30/35	mm	130.0	106.0	–	40.0	15.0	22.0	M6 x 1.0
	(inch)	5.12	4.17	–	1.57	0.59	0.87	
60/100/200	mm	150.0	7.0	19.0	35.0	15.0	40.0	M6 x 1.0
	(inch)	5.91	0.28	0.75	1.38	0.59	1.57	

## Low Profile Single-Point

SPECIFICATIONS				
PARAMETER	VALUE			UNIT
NTEP/OIML accuracy class	NTEP III	Non-Approved	C3	
Maximum no. of intervals (n)	5000 single <sup>(1)</sup>	1000	3000 <sup>(2)</sup>	
$Y = E_{max}/V_{min}$	8000	1400	6000	Maximum available 12000
Standard capacities ( $E_{max}$ )	0.6, 1, 2, 3, 6, 10, 15, 20, 30, 35, 60, 100, 200			kg
Rated output—R.O.	2.0 <sup>(3)</sup>			mV/V
Rated output tolerance	10			±% of rated output
Zero balance	3			±% of rated output
Non-linearity	0.025	0.030	0.020	±% of rated output
Hysteresis	0.025	0.030	0.020	±% of rated output
Non-repeatability	0.020			±% of rated output
Creep error (20 minutes)	0.030	0.030	0.017	±% of rated output
Zero return (20 minutes)	0.030	0.030	0.017	±% of rated output
Temperature effect on min. dead load output	0.0026	0.0026	0.014	±% of rated output/°C
Temperature effect on sensitivity	0.0015	0.0015	0.008	±% of applied load/°C
Compensated temperature range	-10 to +40			°C
Operating temperature range	-20 to +60			°C
Safe overload	150			% of R.C.
Ultimate overload	200			% of R.C.
Excitation, recommended	10			VDC or VAC RMS
Excitation, maximum	15			VDC or VAC RMS
Input impedance	410±10			Ω
Output impedance	350±3			Ω
Insulation resistance	>5000			MΩ
Construction	Anodized aluminum			
Environmental protection	IP66			

### Notes

<sup>(1)</sup> Capacities 3–30 kg

<sup>(2)</sup> Capacities 6–35 kg

<sup>(3)</sup> 1 mV/V for 1 kg and below

All specifications subject to change without notice.

### FM Approval

Intrinsically Safe: Class I, II, III; Div. 1 Groups A-G

Non-Incendive: Class I; Div. 2 Groups A-D